

## ARTICLE 33-18

### WATER WELL CONTRACTORS

#### Chapter

33-18-01	Water Well Construction and Water Well Pump Installation
33-18-02	Ground Water Monitoring Well Construction Requirements

#### CHAPTER 33-18-01

### WATER WELL CONSTRUCTION AND WATER WELL PUMP INSTALLATION

#### Section

33-18-01-01	Responsibility
33-18-01-02	Definitions
33-18-01-03	Plans and Specifications
33-18-01-04	Location of Wells
33-18-01-05	Protection of Ground Water Sources
33-18-01-06	General Well Construction Requirements
33-18-01-07	Pump Installation for Water Wells
33-18-01-08	Storage Tanks
33-18-01-09	Materials for Water Distribution
33-18-01-10	Cross-Connection Control

**33-18-01-01. Responsibility.** It is the responsibility of any person, partnership, association, or corporation engaged in the business of construction of water wells, the installation of water well pumps, pitless units, or other appurtenances, or both, or drilling of geothermal systems, to comply within the meaning of this chapter pursuant to North Dakota Century Code chapters 23-01, 43-35, and 61-28.1.

A person, partnership, association, or corporation may not engage in the business of water well construction, the installation of water well pumps, pitless units, or other appurtenances, or both, or drilling of geothermal systems, unless a certified water well contractor, water well pump and pitless unit installer, or geothermal system driller is in charge.

The certified water well contractor, water well pump and pitless installer, or geothermal system driller in charge shall provide inspection and supervision of all water well construction activities, installation of water well pumps, pitless units, or other appurtenances, or both, or drilling of geothermal systems.

**History:** Amended effective January 1, 1984; April 1, 1997; July 1, 2008.

**General Authority:** NDCC 43-35-19

**Law Implemented:** NDCC 43-35-19

**33-18-01-02. Definitions.** For the purpose of this chapter, the following definitions shall apply:

1. "Abandoned well" means a well whose use has been permanently discontinued.
2. "Annular space" means the opening between a well hole excavation and the well casing or curb, or between a casing pipe and a liner pipe.
3. "Appurtenances" means valves, meters, taps, gauges, or other devices required for adequate control or measurement of the well output.
4. "Aquifer" means a water-bearing formation that transmits water in sufficient quantities to supply a well.
5. "Casing" shall mean the pipe installed in the drill hole to give unobstructed access to the water-bearing formation.
6. "Constructing" a well includes boring, digging, drilling, or excavation in installing casings, well screens, and other appurtenances.
7. "Contamination" means alteration of the physical, chemical, or biological quality of the water so that it is harmful or potentially injurious to the health of the users or for the intended use of the water.
8. "Department" means the North Dakota state department of health.
9. "Disinfection" means the killing of infectious agents outside the body by chemical or physical means.
10. "Drawdown" means the extent of lowering the water surface in a well and of the water table adjacent to the well, resulting from the discharge of water from the well by pumping or natural flow.
11. "Drilling" means making any opening in the earth's surface by drilling, boring, or otherwise, and includes inserting any object into any part of the earth's surface for the purpose of obtaining an underground water supply except drainage tiles or similar devices designed primarily to improve land by removing excess water.
12. "Established ground surface" means the permanent elevation of the surface of the ground at the site of the well.
13. "Filter pack" means a clean sand or sand and gravel material of selected grain size and gradation which is installed in the annular space between a well hole excavation and the outside of the well screen for the purpose of preventing formation material from entering the screen.
14. "Geothermal system driller" means any person who is certified to conduct the business of drilling, boring, or excavating for the purpose of constructing or substantially modifying a geothermal energy extraction facility.

15. "Ground water source" means all water obtained from dug, drilled, bored, or driven well, infiltration lines, and springs.
16. "Grout" or "grouting material" means any stable impervious bonding material which is capable of providing a watertight seal between the casing and the formation throughout the depth required to protect against objectionable matter and which is reasonably free of shrinkage.
17. "Liner pipe" means a pipe installed inside a completed and cased well for the purpose of sealing off undesirable water or for repairing ruptured or punctured casing or screens.
18. "Pitless adapter" means a commercially manufactured device designed for attachment to a well casing and is so constructed as to prevent the entrance of contaminants into the well or potable water supply, conduct water from the well below the frostline to prevent freezing, and provide full access to the water system components within the well.
19. "Pitless unit" means a factory-assembled device with cap which extends the upper end of a well casing to above grade and is so constructed as to prevent the entrance of contaminants into the well or potable water supply, conduct water from the well below the frostline to prevent freezing, and provide full access to the well and the water system components within the well.
20. "Potable water" means water free from impurities in amounts sufficient to cause disease or harmful physiological effects, with the bacteriological and chemical quality conforming to applicable standards.
21. "Pressure tank" or "hydropneumatic tank" means a closed water storage container constructed to operate under a designed pressure rating to modulate the water system pressure within a selected range.
22. "Private water supply" means one that is not for public use.
23. "Public water supply" means a water supply connected to at least fifteen service connections or regularly serves an average of twenty-five persons daily, sixty days out of the year.
24. "Pumps" and "pumping equipment" means any equipment or materials utilized or intended for use in withdrawing or obtaining ground water for any use, including, without limitation, seals and tanks, together with fittings and controls.
25. "Repair" means any action which results in a breaking or opening of the well seal or replacement of a pump.

26. "Shall" means mandatory compliance with all aspects of the rules and regulations for water well construction and water well pump installation.
27. "Should" means provisions which are not mandatory but which are recommended or desirable procedures or methods. Deviation from the rules and regulations for water well construction and water well pump installation is subject to individual consideration.
28. "Static water level" means the elevation of the surface of the water in a well when no water is being discharged therefrom.
29. "Water well contractor" means any person who is certified to conduct the business of well drilling under the provisions of North Dakota Century Code chapter 43-35.
30. "Water well pump and pitless unit installer" means any person who is certified to conduct the business of installing water well pumps and pitless units under the provisions of North Dakota Century Code chapter 43-35.
31. "Well development" means the general process to achieve sand-free water at the highest possible well capacity.
32. "Well seal" means an approved arrangement or device used to cap a well or to establish and maintain a junction between the casing or curbing of a well and the piping or equipment installed therein, the purpose or function of which is to prevent pollutants from entering the well at the upper terminal.
33. "Well vent" means an outlet at the upper terminal of the well casing to allow equalization of air pressure in the well and escape of toxic or inflammable gases.
34. "Wells" means any artificial opening or artificially altered natural opening however made by which ground water is sought or through which ground water flows under natural pressure or is artificially withdrawn; provided, that this definition does not include a natural spring, stock ponds, or holes drilled for the purpose of exploration for production of oil, gas, gravel, or other minerals.

**History:** Amended effective September 1, 1986; April 1, 1997; July 1, 2008.

**General Authority:** NDCC 43-35-19, 43-35-19.1

**Law Implemented:** NDCC 43-35-19, 43-35-19.1

**33-18-01-03. Plans and specifications.** No public water well shall be constructed or modified, or water well pump, pitless unit, or other appurtenances be installed without prior approval of plans and specifications. Plans and specifications shall be submitted to the department for review prior to construction. Note chapter 33-03-08. The plans and specifications shall include:

1. Proposed well location.
2. Location and depths of existing wells, location of septic tanks, absorption fields, sewers, barnyards, feedlots, landfills, and high water marks of lakes or streams with a radius of five hundred feet [152.4 meters].
3. Elevation of highest known flood levels, upper terminal of well casing, floor of structure, and outside grade.
4. A schematic drawing of the well construction showing diameter and depth of drill holes, casing and liner diameters and depths, grouting depths, and other details as necessary to completely describe the proposed well.
5. Certification that the state engineer, North Dakota state water commission, has issued a conditional water permit for the beneficial use of water from the well to be constructed, if such a permit is required pursuant to North Dakota Century Code section 61-04-02.

Routine maintenance and repair does not require submission of plans and specifications.

**History:** Amended effective January 1, 1984.

**General Authority:** NDCC 43-35-19

**Law Implemented:** NDCC 43-35-19

#### **33-18-01-04. Location of wells.**

1. **Relation to sources of contamination.** Determination of minimum lateral distances of a well from potential sources of contamination, involves evaluation of the character and location of the sources of contamination, types of geologic formations, depth to the aquifer, effect on ground water movement by well pumping, and possibilities of flooding of the site by surface waters.

Based on experience, accepted minimum lateral distances for some common sources of pollution with respect to a well have been established. The lack of specific distances for other possible sources of contamination such as refuse disposal sites, excavations, waste treatment facilities, buried oil and gasoline storage tanks, improperly constructed wells and cisterns, etc., does not minimize their potential hazards.

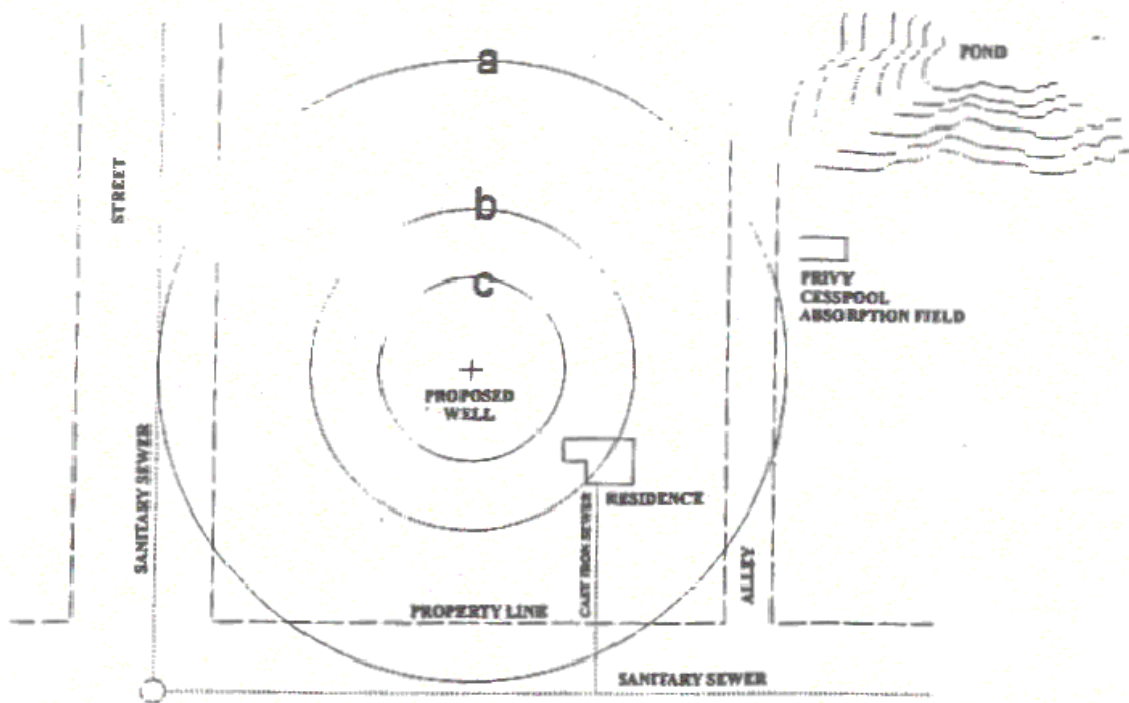

The site should be on high ground and be:

- a. At least one hundred feet [30.48 meters] (fifty feet [15.24 meters] for private wells) from privy pits, cesspools, septic tanks, absorption fields, barnyards, feedlots, high water marks of lakes, streams, sloughs, ponds, etc., when well is constructed in unconsolidated soils with filtering properties.
- b. At least thirty feet [9.14 meters] from sewerlines.
- c. At least ten feet [3.05 meters] from basements or pits.
- d. At least twenty feet [6.1 meters] from overhead powerlines and other hazardous devices. Note North Dakota Administrative Code section 24-02-01-03.

Greater distances are always preferable and often necessary, depending upon soil conditions. When wells are constructed in consolidated formations, care must be taken in locating the wells as pollutants have traveled great distances in such formations.

2. **Relation to buildings.** When a well must be located adjacent to a building, it shall be located so that the centerline of the well extended vertically will clear any projection from the building by not less than two feet [60.96 centimeters].

Every well shall be reasonably accessible for proper repair, cleaning, testing, inspection, or other attention as may be necessary.

The well casing shall not extend through nor shall the top of the well casing or any other well opening terminate in the basement of any building or in a pit, room, or other space which is below ground surface.

**History:** Amended effective January 1, 1984.

**General Authority:** NDCC 43-35-19

**Law Implemented:** NDCC 43-35-19

### **33-18-01-05. Protection of ground water sources.**

1. **Minimum protective depths of wells.** All wells shall be watertight to exclude contamination. Wells shall be designed to seal off formations that are or may be contaminated or undesirable.

Unless approved otherwise by the department, the annular space between a well hole excavation and the outside of the well casing shall be filled with neat cement grout, high-solids bentonite clay grout, bentonite chips, or bentonite tablets at least one and one-half inches [3.81 centimeters] in thickness from a depth of not less than thirty feet [9.1 meters] to the ground surface or the upper end of the well casing if a pitless unit or adapter is installed. Wells with a depth of thirty feet [9.1 meters] or less shall be grouted from within two feet [60.96 centimeters] of the top of the well screen to the ground surface or the upper end of the well casing if a pitless unit or adapter is installed. Greater depths are preferable and may be required for specific installations as determined by review of the plans and specifications.

The annular space of wells constructed in unconsolidated formations without overlying confining beds and static water levels less than thirty feet [9.1 meters] below the ground surface shall be filled with neat cement grout, high-solids bentonite clay grout, bentonite chips, or bentonite tablets at least one and one-half inches [3.81 centimeters] in thickness from the static water level or a depth of not less than ten feet [3.0 meters], whichever is greater, to the ground surface or the upper end of the well casing if a pitless unit or adapter is installed.

Driven well casing may, when conditions warrant, be installed without grouting.

2. **Required protection for various sources.**
  - a. Radial collector wells. The location of all caisson construction joints and porthole assemblies shall be indicated. The caisson wall shall be substantially reinforced. Radial collectors shall be in areas and at depths approved by the department. Provisions shall be made to assure minimum vertical rise. The top of the caisson shall be

covered with a watertight floor. All openings in the floor shall be curbed and protected from entrance of foreign material. Pump discharge piping shall not be placed through caisson walls.

- b. Dug or bored wells. Dug or bored wells greater than two feet [60.96 centimeters] in diameter shall be developed only where geological conditions preclude the development of a satisfactory drilled well.

Every dug or bored well shall have a continuous watertight casing. The section of casing in the producing zone serving as the well screen shall readily admit water and be structurally sound to withstand external pressures.

The open space between the excavation and the installed casing shall be sealed with neat cement grout, high-solids bentonite clay grout, bentonite chips, or bentonite tablets.

The watertight casing shall extend at least twelve inches [30.48 centimeters] above finished ground surface. A cover slab at least four inches [10.16 centimeters] thick, adequately reinforced and having a diameter sufficient to overlap the lining by two inches [5.08 centimeters] shall be provided. The slab shall be constructed without joints.

The top of the slab shall be sloped to drain to all sides and a watertight joint made where the slab rests on the well casing using cement mortar or a mastic compound.

A manhole, if installed, shall be provided with a curb cast in the slab and extending at least four to six inches [10.16 to 15.24 centimeters] above the slab. The manhole shall have a watertight overlapping cover extending down around the curb by at least two inches [5.08 centimeters].

Adequate sized pipe sleeve or sleeves shall be cast in place in the slab to accommodate the type of pump or pump piping proposed for the well.

- c. Infiltration wells. Infiltration wells may be considered where geological conditions preclude possibility of developing an acceptable drilled well. The area around the well shall be under the control of the water purveyor for a distance acceptable to or required by the department. The flow in the lines shall be by gravity to a collecting well. The water shall be continuously chlorinated to assure bacterial purity.
- d. Flowing wells. The construction of flowing wells shall be in compliance with North Dakota Century Code chapter 61-20.



The construction of flowing wells shall be such that the flow from them can be controlled. Well casing shall be installed, and the annular space grouted with neat cement to form a tight seal. The neat cement grout shall extend upward from within twenty feet [6.1 meters] of the top of the aquifer to the ground surface or the upper end of the well casing if a pitless unit or adapter is installed.

Well casings shall be joined in a watertight manner. Flow control should consist of valved pipe connections, watertight pump connections, or receiving reservoirs set at an elevation corresponding to the artesian head.

- e. Existing wells. The department shall be consulted for requirements concerning the reconstruction of existing wells.

**History:** Amended effective January 1, 1984; September 1, 1986; April 1, 1997.

**General Authority:** NDCC 43-35-19, 43-35-19.1

**Law Implemented:** NDCC 43-35-19, 43-35-19.1

### **33-18-01-06. General well construction requirements.**

1. **Construction water.** Water used in the drilling process shall be obtained from a source which will not result in contamination of the well. Chlorination of the water with an initial dosage of not less than fifty milligrams per liter (one gallon [3.78 liters] of laundry bleach or 0.6 pounds [1.32 kilograms] of calcium hypochlorite per one thousand gallons [3.78 kiloliters] of drilling water) is recommended.

Waters from surface sources must be chlorinated with a minimum dosage of one hundred milligrams per liter (two gallons [7.56 liters] of laundry bleach or 1.2 pounds [2.64 kilograms] of calcium hypochlorite per one thousand gallons [3.78 kiloliters] of drilling water).

2. **Ferrous well casing.**

- a. General. Casing and liner pipe of wrought iron or steel through ten inches [25.4 centimeters] in diameter shall be prime pipe meeting current American Society for Testing and Materials Schedule 40, or equivalent specifications. Larger diameter pipes shall have a minimum wall thickness of three hundred seventy-five thousandths of an inch [0.952 centimeter].

All casing shall have additional thickness and weight if standard thickness is not considered sufficient to assure reasonable life expectancy of the well or be capable of withstanding forces to which they are subjected.

- b. Drive shoe. Pipe that is to be driven shall be equipped with a drive shoe or other device approved by the department.

- c. Joints. Casing and liner pipe joints shall be properly welded or threaded.
- 3. **Nonferrous well casing.**
  - a. General. Pipe other than wrought iron or steel must be adaptable to the stresses to which they will be subjected during and after installation and to the corrosiveness of the water.
  - b. Thermoplastic well casing. Thermoplastic well casing shall conform with American Society for Testing and Materials Specification F480-81 or latest revision as follows:
    - (1) Minimum standard dimension ratio shall be twenty-one for casings less than sixteen inches [40.64 centimeters] in diameter. Minimum standard dimension ratio shall be twenty-six for casings sixteen inches [40.64 centimeters] in diameter or larger. Casings with a lower standard dimension ratio (additional thickness) must be used when the minimum standard dimension ratio is not capable of withstanding the stresses encountered during and after installation.
    - (2) Minimum pipe stiffness shall be two hundred twenty-four pounds/foot [inch · inch] (kiloneutron/[meter · meter]) when tested according to section 5.4.1 of American Society for Testing and Materials Specification F480.
    - (3) All casing five inches [12.7 centimeters] and larger shall be tested for impact resistance and meet or exceed IC-1 impact classification according to section 6.5 and table 6 of American Society for Testing and Materials Specification F480.
  - c. Other materials. Other well casing materials that may be proposed shall carry the seal of the national sanitation foundation and be approved in writing by the department prior to installation.
- 4. **Packers.** Packers shall be of a material that will not impart taste, odors, toxic substances, or bacterial contamination to the water in the well.
- 5. **Screens.** Screens must be constructed of corrosion-resistant material and sufficiently strong to withstand stresses encountered during and after installation. Screen slot openings, screen length, and screen diameter should be sized and designed to provide sufficient open area consistent with strength requirements to transmit sand-free water at a capacity at least equal to one and one-half times the capacity of water anticipated. Screen slot size should be based on sieve analysis of formation samples.

Screens should be installed so that exposure above pumping level will not occur. A screen must be attached or connected to the casing by a threaded, solvent-welded, or welded joint or by threaded fasteners or a nontoxic packer. Solvent-welded joints should not impart taste, odors, toxic substances, or bacterial contamination to the water in the well.

6. **Filter pack.** Material used as a filter pack shall be sand or sand and gravel that is free of foreign material, properly sized, washed, and then disinfected prior to or during placement. Provisions for prevention of leakage of grout into the filter pack or screen shall be provided.
7. **Well development.** Every well shall be developed prior to yield and drawdown testing. Well development includes procedures to apply physical energy to the screen and aquifer formation adjacent to the well. After development, the well should produce sand-free water at a capacity at least equal to one and one-half times the capacity of water anticipated.
8. **Yield and drawdown test.** Every well should be tested for yield and drawdown. The test method to be followed should be clearly outlined in the specifications. The test pump should have a maximum capacity at least equal to one and one-half times the capacity of water anticipated. The test pump should be able to operate continuously until the rate of decline of the pumping water level has stabilized. Test data to be recorded should include:
  - a. Static water level.
  - b. Pumping rate.
  - c. Drawdown during test.
  - d. Recovery water levels.
  - e. Depth of pump setting.

Duration of the test shall be determined with due consideration given to pumping of sand, clarity of water pumped, and the obtaining of a representative sample of water for chemical analysis.

9. **Chemical conditioning.** When chemical treatment of a public well is proposed, the method of conditioning shall be included in the specifications. The equipment, chemicals, and inhibitors to be used, the method of testing for chemical residuals, and the disposal of waste shall be indicated.
10. **Grouting requirements.**

- a. Neat cement grout. The mixture should consist of one sack of cement (ninety-four pounds [42.64 kilograms]) to not more than six gallons [22.71 liters] of clean water. Bentonite additives up to five pounds [2.27 kilograms] per sack of cement to increase fluidity may be used. Pozzuolana additives up to thirty-three pounds [14.97 kilograms] per sack of cement may be used.
- b. Heat of hydration. Care must be used when grouting thermoplastic well casing with neat cement grout. Heat caused by hydration during curing of the cement may cause weakening of the well casing. High peak temperatures may be minimized by adding sand or bentonite clay to the neat cement grout mixture to increase the curing time. The amount of sand or bentonite clay added to the neat cement grout may not exceed five pounds [2.27 kilograms] per sack of cement.
- c. High-solids bentonite clay grout. The mixture must consist of not less than three pounds [1.36 kilograms] of bentonite clay per gallon [3.79 liters] of clean water.

High-solids bentonite clay grout, bentonite chips, or bentonite tablets must be commercially prepared specifically for the purpose of sealing water wells. The use of bentonite drilling fluids as a grouting material is not permitted.

- d. Grouting guides. Casing that is to be grouted in the drill hole or annular opening shall be provided with sufficient guides welded to the casing to permit the unobstructed flow and uniform thickness of grout.
- e. Grout application. Grout material must be positively and accurately placed to fill all voids. All grouting should be performed by adding the mixture, from the bottom of the annular space upward, in one continuous operation, until the annular space is filled. Sufficient annular opening shall be provided to permit a minimum of one and one-half inches [3.81 centimeters] of grout around the casing, including couplings, if used.

Bentonite chips or tablets may be added from the top of the annular space to a maximum depth of thirty feet [9.1 meters] provided the grout material is positively and accurately placed to fill all voids and hydrated after placement.

- 11. **Plumbness and alignment.** Every well shall be tested for plumbness and alignment upon completion of construction. The casing shall be sufficiently plumb so as not to interfere with the installation and operation of the pump. (See recommended procedures in the appendix to this chapter.)

12. **Well construction data.** The water well contractor shall provide the North Dakota board of water well contractors with an accurate record of well construction data. Drill cuttings should be obtained at five-foot [1.52-meter] intervals, and at all pronounced changes in formation. Well construction data shall include an accurate record of the drill hole diameters and depths, assembled order of size and length of casings and liners, grouting depths, formations penetrated, water levels, location of blast shots, and pumping tests. Well construction report forms are available from the North Dakota board of water well contractors.

13. **Upper terminal of well.** The casing or pitless unit for all ground water sources shall project not less than twelve inches [30.48 centimeters] above the final ground elevation, the well cover slab, or pumphouse floor.

Sites subject to flooding shall have the top of the protective casing, pitless unit, the cover of every dug well, and the floor of the pumphouse at least two feet [60.96 centimeters] above the highest-known flood elevation and be surrounded by earthfill.

14. **Capping.** The well must be protected during construction. A properly fitted cap designed for the type of well casing installed shall be used to protect the well from surface contamination until pumping equipment is installed.

15. **Bacteriological and chemical quality of water.** Every new, modified, or reconditioned ground water source shall be thoroughly cleaned and disinfected after the completion of construction and again after the permanent pump has been installed. The certified water well contractor or pump and pitless unit installer in charge during well construction and pump installation shall advise the well owner that one or more water samples from the source should be submitted to an approved laboratory for bacteriological analysis and that the well should not be placed into service until satisfactory bacteriological results are obtained.

Wells intended for use by a public water system shall be sampled for bacteriological analysis and the following chemicals and not placed into service until the results are deemed by the department to comply with the primary drinking water standards established under the Safe Drinking Water Act: antimony, arsenic, barium, beryllium, cadmium, chromium, copper, cyanide, fluoride, lead, mercury, nickel, combined nitrate/nitrite, selenium, thallium, manganese, and sulfate. When it is established that the ground water is subject to continuous or intermittent contamination, or for public water systems that the ground water is under the direct influence of surface water, provisions for continuous disinfection will be required.

16. **Chemical quality of water.** Every new, modified, or reconditioned ground water source should be examined for its chemical characteristics by tests of a representative sample in a department or other approved laboratory. The samples should be collected and tested as soon as practical.
17. **Water level measurement.** Provisions should be made for periodic measurement of the static and pumping water levels in the completed well. The installation shall be made in such manner as to prevent the entrances of foreign material.
18. **Water supply wells, geothermal ground water and return wells, and special purpose water wells.** All wells designed as water supply wells, geothermal ground water or return wells, or special purpose water wells shall be constructed in accordance with this chapter.

Each well shall be protected at its upper terminal to preclude the entrance of foreign materials.

19. **Abandoned wells.** Any abandoned water wells, including test wells, uncompleted wells, and completed wells shall be sealed by restoring, as far as possible, the controlling geological conditions which existed before the wells were drilled.

Sealing of wells results in:

- a. Elimination of physical hazards.
- b. Prevention of contamination of ground water.
- c. Conserving yield and hydrostatic head of aquifers.
- d. Prevention of intermingling of desirable and undesirable waters.

Wherever feasible, the wells should be filled with concrete grout or other approved materials. (Note: recommended grouting procedures are in the appendix to this chapter.)

At no time shall any sewage or other contaminated or toxic materials be discharged into an abandoned well.

20. **Organic polymers.** The use of biodegradable organic polymers as a drilling fluid additive has resulted in persistent microbiological contamination of ground water supplies. Organic polymers shall be

used only when approved in writing by the department for a specific well construction project.

**History:** Amended effective January 1, 1984; September 1, 1986; April 1, 1997; July 1, 2008.

**General Authority:** NDCC 43-35-19, 43-35-19.1, 43-35-19.2

**Law Implemented:** NDCC 43-35-19, 43-35-19.1, 43-35-19.2

### **33-18-01-07. Pump installation for water wells.**

1. **Pumphouse appurtenances.** The installation of necessary appurtenances for public wells shall be as illustrated in pump installation details contained in the diagrams attached to this chapter.
  - a. Floor drain. The pumphouse floor shall be watertight and shall slope away from the pump base. The pumphouse floor shall be provided with a floor drain discharging to a sump at least twenty-five feet [7.62 meters] from the well.
  - b. Vents. Provisions shall be made for venting the well casing to the atmosphere. There shall be no holes in the pump base which might allow wastewater or other material to enter the well. A breather tube shall be installed of sufficient size to permit air to enter and leave the well freely with the changing of water elevation caused by starting and stopping the pump. The breather tube shall terminate in a full one-hundred-eighty-degree bend at least eighteen inches [45.72 centimeters] above the floor, securely screened with sixteen mesh wire screen. If the breather tube or a depth gauge line passes through the base of the pump or through the seal connection into the well, the hole about the tube shall be sealed.
  - c. Water level measurement. An access plug for a measuring tape or an air line and drawdown gauge for determining location of the water level shall be installed during the installation of the pump on all public wells. Installation of permanent water level measuring equipment shall be made using corrosion-resistant materials firmly attached, in a vertical position, to the drop pipe or pump column in such a manner as to prevent entrance of foreign materials. The air line shall extend from the top of the well to several feet [meters] below the lowest anticipated water level. The length of the air line shall be accurately measured and the length recorded.
2. **Cutting of well casing.** No casing shall be cut off or cut into below ground level except to install a pitless unit or adapter.
3. **Pitless unit and adapter.**

a. Pitless unit. Pitless units designed to replace a section of well casing must meet the standards of the national sanitation foundation or the water systems council and must:

- (1) Be factory fabricated from point of connection with the well casing to the unit cap or cover. The materials used must be durable, at least equal in quality to the well casing, to prevent excessive corrosion.
- (2) Form an unbroken extension of the well casing from the point of discharge to a point above ground level as specified for upper well terminals.
- (3) Have an inside diameter equal to or greater than the inside diameter of the well casing to facilitate work and repair on the well, pump, or well screen. Any deviation from this paragraph must be approved in writing by the department.
- (4) Conduct water from a well casing without exposing the well to contamination through openings in the casing.
- (5) Have access to the casing for disinfection of the well.
- (6) Be capped with a cover having a downward flange which will overlap the edge of the unit. The cover must be securely fastened to the unit and must be sufficiently snug to the unit to be verminproof or watertight if required.

The cover must provide for watertight entrance of electrical cables, vent piping, and an air line or a tap for wetted tape measurements of depth to water level of a well.

- (7) Be installed by threaded, welded, or compression flange gasketed connection to the cutoff casing. The threaded, welded, or compression flange gasketed connection to the cutoff casing must be watertight. If the connection to the casing is to be a field weld, the factory-assembled unit must be designed specifically for field welding.
- (8) Have all field connections between the pitless unit and the water service pipe threaded, flanged, or mechanical joint.

b. Pitless adapter. Commercially manufactured clamp-on or weld-on pitless adapters for attachment to the exterior of a well casing may be installed when approved by the department. Pitless adapters must be installed according to manufacturer's specifications and meet the standards of the national sanitation foundation. A list of approved pitless adapters is available from the department.



- (1) Pitless adapters must be constructed and installed so as to prevent the entrance of contaminants into the well or water supply through openings in the well casing.
  - (2) The pitless adapter must provide adequate clearance within the well to permit insertion and withdrawal of the pump and system components through the upper terminal of the well casing.
  - (3) The pitless adapter must be connected to the well casing with clamps-and-gasket or by welding and must be watertight. To assure a watertight connection between the pitless adapter and the well casing, care must be used in cutting the hole in the well casing, preferably with a hole-cutting saw. All burrs from the cutting process must be removed. Both the outside and the inside surfaces of well casing surrounding the hole must be smooth.
  - (4) A pitless cap or cover must enclose the upper terminal of the well casing. The cap, entrance of electrical cables, vent piping, air lines, etc., must be as specified for pitless units.
  - (5) All field connections between the pitless adapter and the water service pipe must be threaded, flanged, or mechanical joint.
  - (6) All other aspects of pitless adapter requirements must be as specified for pitless units.
- c. Freezing. Water service piping must be installed below recorded frost penetration. A minimum depth of seven feet [2.28 meters] below grade is recommended to prevent freezing.
4. **Over-the-well pumps.** Power-driven pumps located over a well shall be installed on a concrete base of sufficient height to permit the outside casing to extend one inch [2.54 centimeters] above the concrete base. On all public water wells, the annular opening between the drill hole and casing shall be filled with cement grout before the pump base and pumphouse floor are constructed. If the well is of the gravel wall type, the outer casing shall extend at least twelve inches [30.48 centimeters] above the pumphouse floor with suitable provisions made for adding gravel. The inner casing shall extend one inch [2.54 centimeters] above the pump base. Note diagrams no. 1 and no. 2, pump installation details, in the diagrams attached to this chapter.

A sanitary well seal shall be installed at the top of the well casing to prevent the entrance of contaminated water or objectionable material.

5. **Pump column.** A separate pump column, suction or discharge pipe shall be installed inside the well casing in all instances, whether the well is to be pumped by suction, airlift, or deep well pump.
6. **Submersible pumps.** The discharge line installed inside of the well casing must meet the standards for ferrous or nonferrous well casing in subsections 2 and 3 of section 33-18-01-06. The discharge line shall leave the well at the top of the casing. The opening between the discharge line and casing or pipe sleeve shall be sealed watertight with an expanding rubber seal or equivalent device. When an underground discharge is desired, a properly installed pitless unit or, when approved by the department, a pitless adapter shall be used.

The electrical cable shall be firmly attached to the pump riser at intervals of twenty feet [6.10 meters] or less.

When a check valve is not part of the pump, a check valve shall be installed on the pump discharge line within the well.

A check valve on the pump discharge line is not required on nonpressurized wells for livestock use that would be damaged by freezing, when an airgap or other cross-connection control protection is provided.

7. **Offset pumps.** Pumps offset from public wells shall be located in an aboveground pumphouse or other building. All portions of suction lines buried below the ground surface between the well and the pump shall be enclosed in a protective pipe of standard thickness and be sealed watertight at both ends.

This requirement shall be considered satisfied if the suction line lies within a pressure discharge line.

Offset pumps for private wells may be located in a basement provided that the pumps and all suction pipes are elevated at least twelve inches [30.48 centimeters] above the floor.

8. **Hand pumps.** Hand pumps shall be of the force type equipped with a packing gland around the pump rod, a delivery spout which is closed and downward directed, and a one-piece bell-type base which is part of the pump stand or is attached to the pump column in a watertight manner.

The bell base of the pump shall be bolted with a gasket to a flange which is securely attached to the casing or pipe sleeve.

9. **Pump controls.**

- a. Public water wells. Pump controls for public water wells must be installed in accordance with the manufacturer's recommendations as shown on approved plans and specifications.
- b. Private water wells. Pump controls for private water wells should be installed in accordance with manufacturer's recommendations and must include:
  - (1) A pressure-activated pump switch.
  - (2) A thermal overload switch.
  - (3) A flow control orifice or a low water level cutoff switch on all pumps having an output in excess of the well capacity.
  - (4) A pressure relief valve on positive displacement pumps.
  - (5) The installation of necessary appurtenances for private water wells should be as illustrated in diagram no. 4 - pitless unit and appurtenances for private wells.

**History:** Amended effective January 1, 1984; September 1, 1986; April 1, 1997.

**General Authority:** NDCC 43-35-19, 43-35-19.1

**Law Implemented:** NDCC 43-35-19, 43-35-19.1

### **33-18-01-08. Storage tanks.**

- 1. **Public water systems.** Storage equipment for public water systems must be as shown on approved plans and specifications.
- 2. **Private water systems.** Storage equipment must be as follows:
  - a. All tanks must be certified under water system council standards for size and pressure.
  - b. Hydropneumatic tanks must have a working pressure rating in excess of the maximum system pressure but not less than seventy-five pounds per square inch [34.02 kilograms per 6.45 square centimeters].
  - c. All tanks must be coated or made of materials resistant to corrosion.
  - d. All tanks must be constructed of materials or coatings which are nontoxic.
  - e. All tanks must be provided with a means of draining.
  - f. Atmospheric storage tanks must be provided with a cover to prevent the entrance of unauthorized persons, dirt, or vermin. The

cover must be vented with a return bend vent pipe having an area not less than the area of the downfeed riser pipe and the vent must be screened with corrosion-resistant screen having not less than fourteen and not more than twenty openings per linear inch [2.54 centimeters].

**History:** Effective September 1, 1986.

**General Authority:** NDCC 43-35-19, 43-35-19.1

**Law Implemented:** NDCC 43-35-19, 43-35-19.1

### **33-18-01-09. Materials for water distribution.**

#### **1. Water service pipe.**

- a. Public water systems. Water service pipe from the well to the point of entrance to a pumphouse or building must be as shown on approved plans and specifications.
- b. Private water systems. Water service pipe from the well to point of entrance to a pumphouse or building must be made of copper, galvanized steel, or approved plastic. Approved plastic (polyvinyl chloride, polyethylene, or polybutylene) must have a minimum pressure rating of one hundred sixty pounds per square inch at seventy-three degrees Fahrenheit [11.25 kilograms per square centimeter at 22.8 degrees Celsius]. Copper tube, when used underground, may not be less than type L. All threaded ferrous pipe and fittings must be galvanized or cement-lined and, when used underground in corrosive soil or filled ground, must be coal tar enamel-coated and threaded joints must be coated and wrapped when installed.

All piping must comply with applicable standards for such piping. Polyvinyl chloride, polyethylene, and polybutylene pipe shall carry the seal of the national sanitation foundation.

Permeation through polyethylene and polybutylene pipes by organic contaminants (including petroleum byproducts) can occur resulting in contamination of water supplies. Where there is known contamination of soils by organics or a high probability that contamination of soils by organics may occur, it is recommended that polyethylene and polybutylene pipe not be used to construct water supply lines.

2. **Fittings.** The materials of which water supply system pipe fittings are made must be compatible with the type of piping materials used in the water supply system.
3. **Material strength.**

- a. All materials used for water piping must be suitable for use with the maximum temperature, pressure, and velocity that may be encountered in the installation, including temporary increases and surges.
- b. When the standards for the piping material used for hot and cold water distribution limit the working pressure or temperature to values lower than usually encountered, the relief valve may be set no higher than the limits of the standard.

**History:** Effective September 1, 1986.

**General Authority:** NDCC 43-35-19, 43-35-19.1

**Law Implemented:** NDCC 43-35-19, 43-35-19.1

**33-18-01-10. Cross-connection control - Backflow protection.** All wells discharging to sources of contamination, such as livestock watering tanks, must be provided with an approved backflow prevention device or an airgap to prevent the backflow or siphonage of contaminants into the well. The airgap should provide a minimum vertical distance between the potable water pipe outlet and the water surface of not less than twice the diameter of the outlet pipe. Greater distances are preferable.

Overflow lines from stock watering tanks or other sources of contamination may not discharge to the well.

Please consult the North Dakota state plumbing code for details.

**History:** Effective September 1, 1986.

**General Authority:** NDCC 43-35-19, 43-35-19.1

**Law Implemented:** NDCC 43-35-19, 43-35-19.1

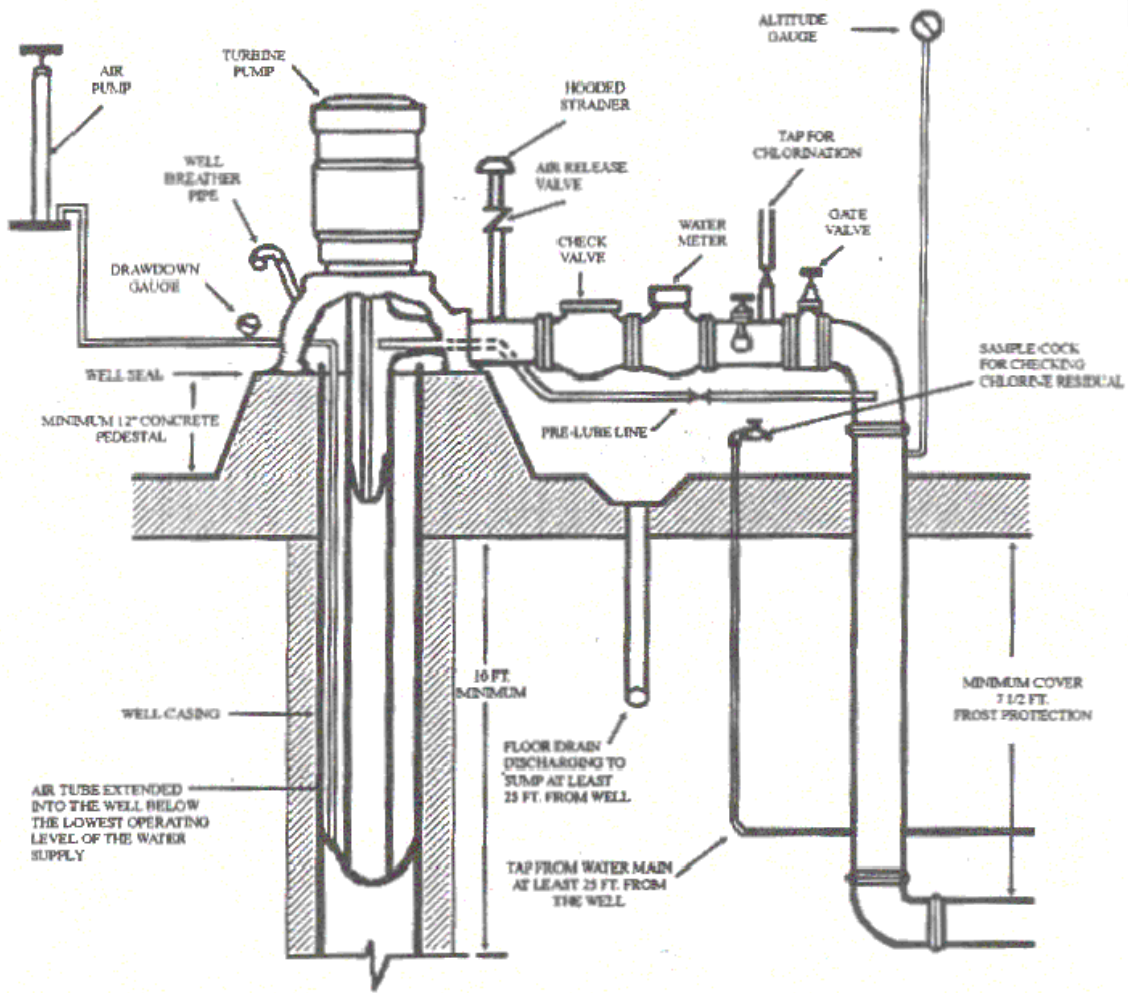

DIAGRAM NO. 1. TURBINE TYPE PUMP AND APPURTENANCES

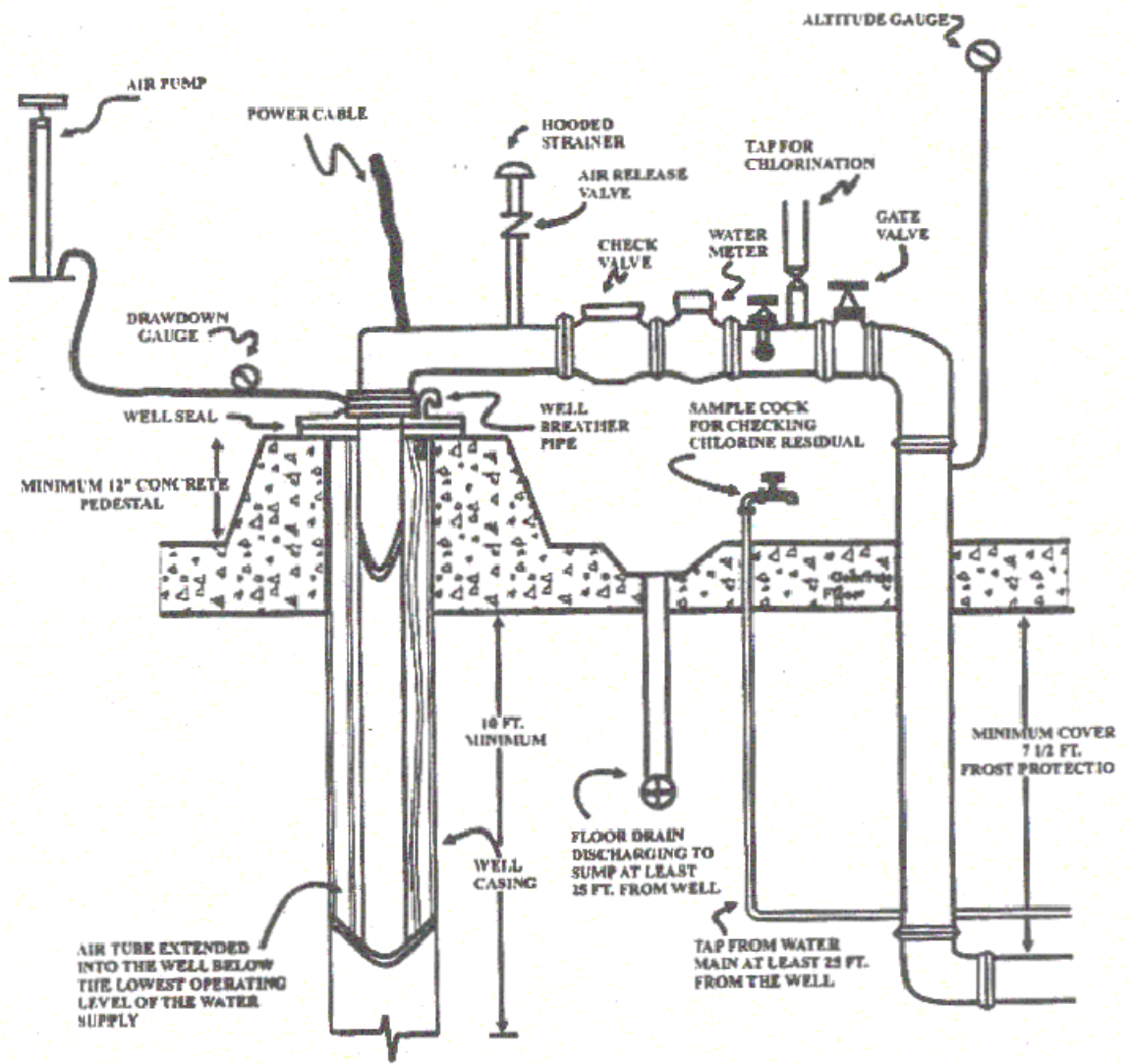

DIAGRAM NO. 2. SUBMERSIBLE TYPE PUMP AND APURTENANCES

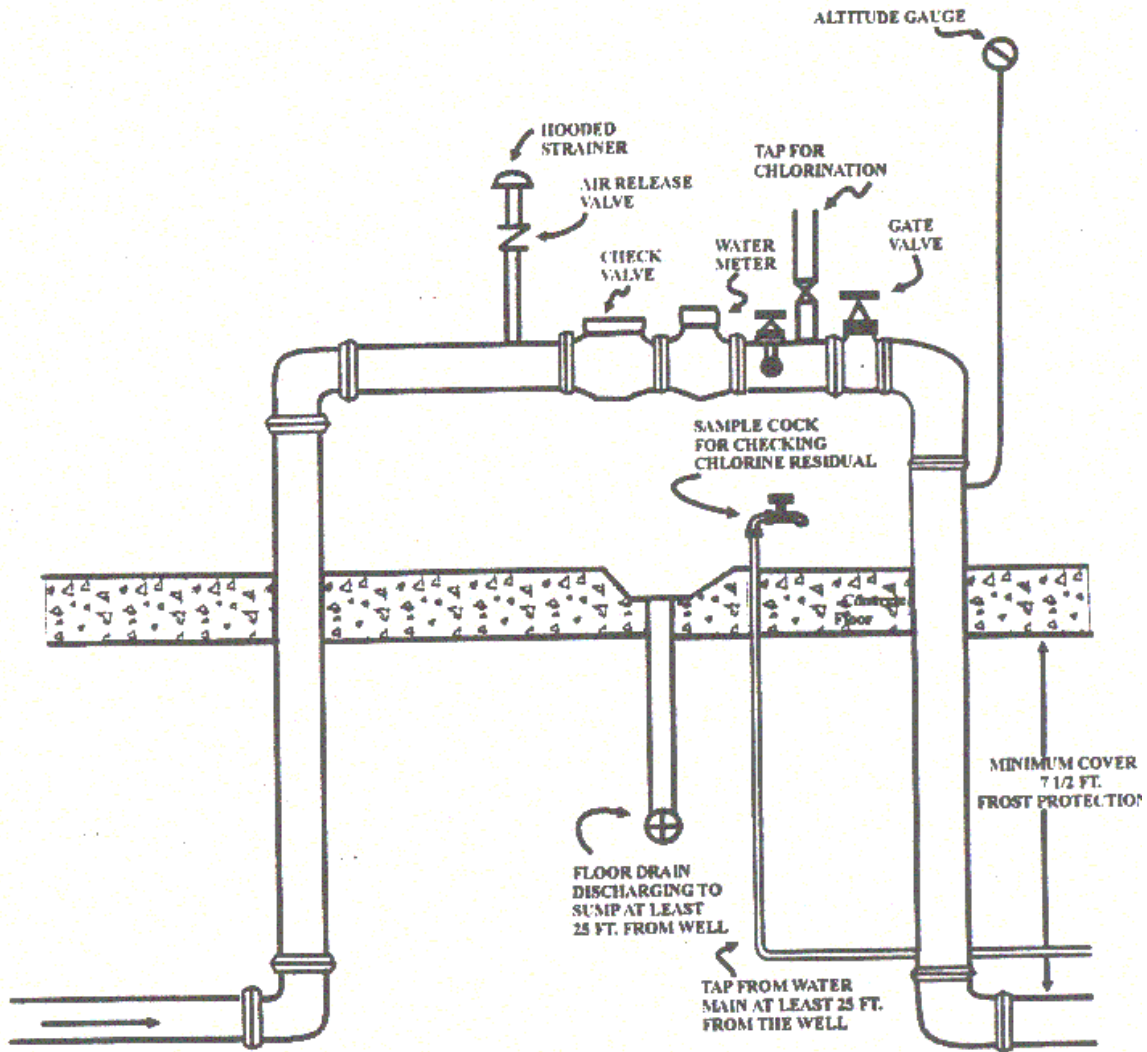

DIAGRAM NO. 3. PITLESS UNIT APPURTENANCES



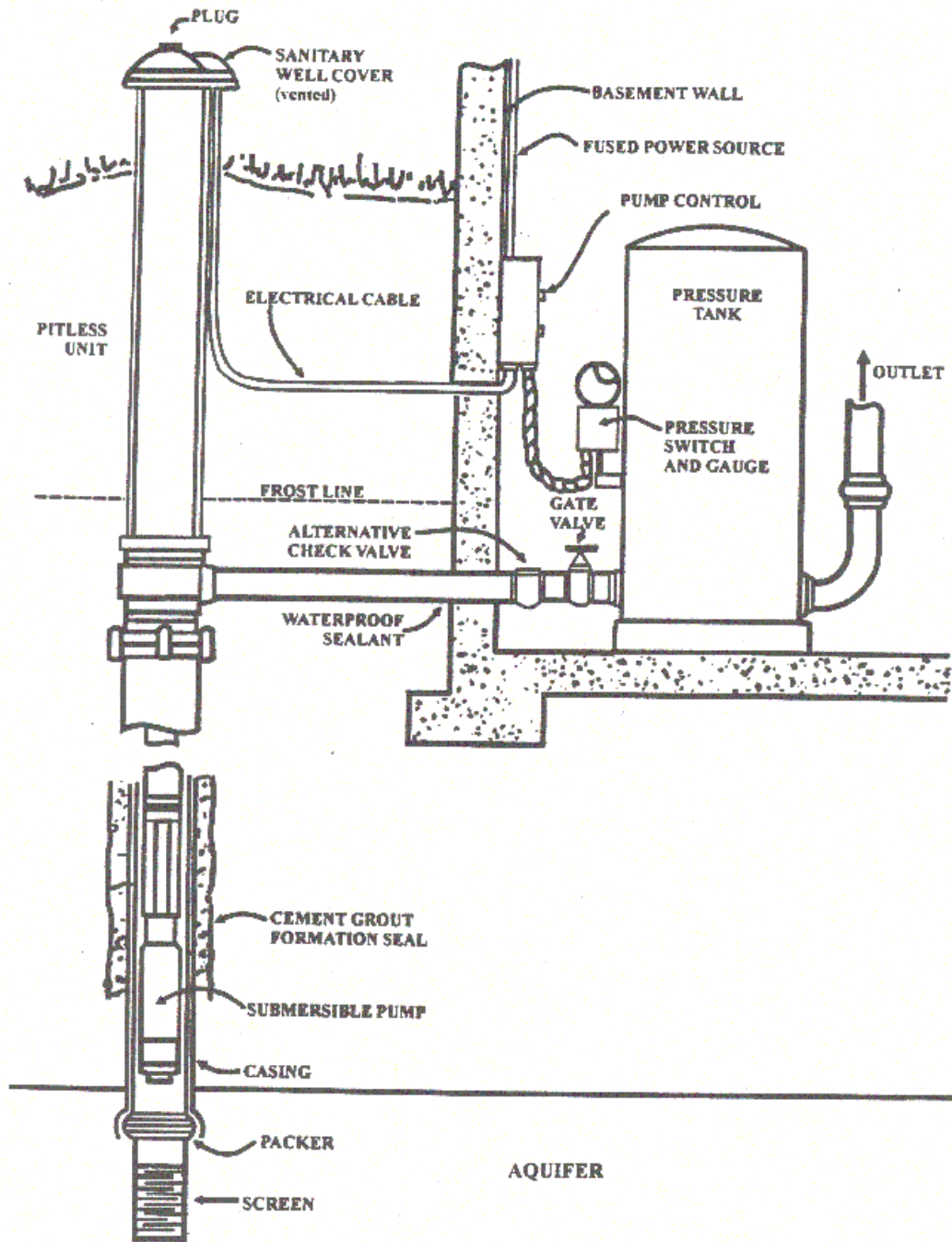

DIAGRAM NO. 4. PITLESS UNIT AND APPURTENANCES FOR PRIVATE WELLS

## APPENDIX

### I. WELL DISINFECTION

#### A. General.

Immediately after construction or repair, always disinfect with a strong chlorine solution of fifty to one hundred milligrams per liter. Materials used in construction or repair of a well are contaminated with dirt and bacteria and the water from a well is considered safe to drink only when laboratory tests show that no harmful bacteria are present.

#### B. Procedure.

1. Determine the amount of water in the well by referring to the table.
2. Add the amount of chlorine compound necessary to give a dosage of fifty milligrams per liter as indicated on the table, into the opening between the casing and the drop pipe. On new well construction, the chlorine should be added just before installation of the pumping equipment.
  - a. Chlorine tablets may be dropped in the top of the well and allowed to settle to the bottom.
  - b. Deep wells with high water levels may require that chlorine solutions be added through a hose inserted down the well casing to ensure proper diffusion of the chlorine.

Chlorine can destroy only the bacteria with which it comes in contact. Agitation of the water in the well may be required to assure thorough mixing. After adding the chlorine, start the pump and operate until the odor of chlorine is detected at the pump discharge.

3. The storage and distribution system should be disinfected along with the well. Open the house faucets and let the water run until the odor of chlorine is apparent.
4. Allow the chlorine solution to remain in the well and distribution system for a period of twenty-four hours. Pump the well and flush the distribution system to remove all traces of chlorine.
5. After pumping, collect a water sample and submit to a laboratory for a bacteriological analysis to assure the safety of the water supply. If contamination is shown to be still present in the water supply, the chlorination procedure should be repeated.
6. When time does not permit well disinfection by the procedure previously described, apply to the entire depth of the well a total volume of 50 mg/l

chlorine solution at least four times greater than the volume of water in the well. Allow the chlorine solution to remain in the well for a period of at least two hours. Pump the well and flush the distribution system to remove all traces of chlorine.

QUANTITY OF DISINFECTANT REQUIRED TO GIVE A DOSE OF 50 MILLIGRAMS PER LITER CHLORINE

Diameter of Well, Spring, or Pipe, in Inches	Gallons of Water Per Foot of Water Depth	Ounces of Disinfectant Per 10-Ft. Depth of Water	
		65% Calcium Hypochlorite	5 1/4% Sodium Hypochlorite*
2	0.16	0.02	0.21
3	0.37	0.04	0.47
4	0.65	0.07	0.83
5	1.00	0.10	1.30
6	1.47	0.15	1.87
8	2.61	0.27	3.32
10	4.08	0.31	5.19
12	5.88	0.60	7.47
18	13.22	1.36	16.80
24	23.50	2.41	29.87
36	52.88	5.43	67.20
48	94.01	9.65	119.47

\*Sodium Hypochlorite, also known as Bleach, Clorox, etc., can be purchased at most drug and grocery stores.

One heaping tablespoon of 65% calcium hypochlorite = approximately 1/2 oz.

Six (6) 65% calcium hypochlorite tablets = approximately 1 oz.

Heavy concentrations of chlorine on or near the well screen with waters very high in iron and/or iron bacteria may result in oxidation of iron on the well screen. Efficiency of the well screen and well output could be reduced under such conditions.

II. LABORATORY SERVICE. Chemical and microbiological laboratory service is provided by the North Dakota state department of health laboratory located at 1205 Avenue A West, Bismarck, North Dakota. Mailing address is:

North Dakota State Department of Health  
 Division of Laboratory Services  
 P.O. Box 937  
 Bismarck, ND 58502

Microbiological laboratory service is available from:

First District Health Unit  
801 11th Avenue SW  
P.O. Box 1268  
Minot, ND 58702-1268

Southwestern District Health Unit  
2869 Third Avenue West  
Dickinson, ND 58601

Fargo Cass Public Health  
Environmental Laboratory  
435 14th Avenue South  
Fargo, ND 58103

Grand Forks Environmental  
Laboratory  
503 South Fourth Street  
Grand Forks, ND 58201

### III. RECOMMENDED PROCEDURES.

#### A. Plumbness and Alignment.

Every public water well, before being officially accepted, should be tested for plumbness and alignment. The test method to be followed should be clearly stated in the specifications. As a minimum, a forty-foot [12.19-meter] section of pipe, or rigid dummy of the same length, having an outside diameter not more than one-half inch [12.7 millimeters] smaller than the diameter of the casing or hole being tested, shall move freely throughout the length of the casing or hole to the lowest anticipated pump setting. The well should not vary from the vertical in excess of two-thirds of the smallest inside diameter of that part of the well being tested, per one hundred feet [30.48 meters] of depth.

#### B. Abandoned Wells.

For detailed procedures for abandoning wells, see Section A1-13, Sealing Abandoned Wells, AWWA Standards for Deep Wells, A100-66 or later amendments prepared by the American Water Works Association and the National Water Well Association.

#### C. Springs.

Springs should be considered as a water supply only when it is not possible to develop an acceptable well. Springs shall be protected from entry of surface water and should be housed in a permanent structure. Continuous chlorination of springs is recommended to assure the bacterial purity of the water supply.

#### D. Continuous Chlorination of Public Well Water Supplies.

Continuous chlorination is recommended for the safeguarding of public well water supplies. Chlorination not only assists in maintaining the bacterial purity of the water, but also eliminates the growth of taste-and-odor-producing nuisance organisms.

#### E. Livestock Wells.

A check valve on the pump discharge line is not required on nonpressurized wells for livestock use that would be damaged by freezing. The pump discharge line shall have a minimum airgap equal to twice the effective diameter of the discharge line to prevent backflow or siphonage into the well to prevent contamination of the well.

### IV. MEASUREMENT OF WATER WELL DRAWDOWN AND SPECIFIC CAPACITY.

Pumping tests of water supply wells can serve many purposes. Properly planned and conducted tests will reveal information about the performance and efficiency of the well being pumped. In addition, from the data obtained, calculations can be made which interpret ground water aquifer performance.

Measuring each well for pump and well yield, depth to water level, drawdown, and specific capacity should be done on a routine basis. These test results should be compared with previous tests to estimate current well and/or aquifer conditions.

#### A. Terminology.

It is important to understand the meaning of the terms used relating to the pumping test. Some of these terms are as follows:

1. **Static Water Level.** This is the level at which water stands in the well when no water is being pumped. It is generally expressed as the distance in feet from the ground surface to the water level in the well.
2. **Pumping Level.** This is the level at which water stands in the well when pumping is in progress. The pumping level may also be referred to as the dynamic water level.
3. **Drawdown.** When a well is pumped, the water level in the vicinity of the well will be lowered. Drawdown is the difference, measured in feet, between the static water level and the pumping level.
4. **Well Yield.** The well yield is the volume of water per unit of time discharged from a well either by pumping or by free flow.
5. **Specific Capacity.** Specific capacity of the well is its yield per unit of drawdown, usually expressed as gallons per minute (gpm) per foot of drawdown.

#### B. Determination of Depth to Water Level.

1. **Wetted Tape Method.** The wetted tape method will accurately measure the depth to water in a well and can be used for depths

up to one hundred feet [30.5 meters] or more. Attach a lead weight to the end of a steel measuring tape, if needed. Wipe dry the lower three or four feet [.91 or 1.22 meters] of the tape and coat with carpenter's chalk. Lower the tape into the well through the air vent or other opening until part of the chalked section is below water. Continue to lower the tape until the next even foot mark can be held exactly at a reference point and record the number of feet indicated. The tape is then removed from the well and note is made of the footage of chalked section washed away by the water. Subtract this reading from the reading obtained at the top reference point. The difference in these readings is the depth from the reference point to the water level.

2. Air Line Method. The air line method measures depth to water level by determining the air pressure required to push all of the water out of a submerged tube of known length. The air line consists of a one-fourth inch [6.35 millimeters] pipe, copper or plastic tubing, extending from the top of the well to a point several feet below the lowest anticipated water level. To avoid turbulence near the intake of the pump, the lower end of the air line should be at least five feet [1.52 meters] above or below the point where water enters the pump. The exact length of the air line must be known or should be measured as it is placed in the well. Make all joints airtight with white lead or piping compound. The upper end of the tube is fitted with suitable connections for an air gauge, a tire valve, and an air pump.

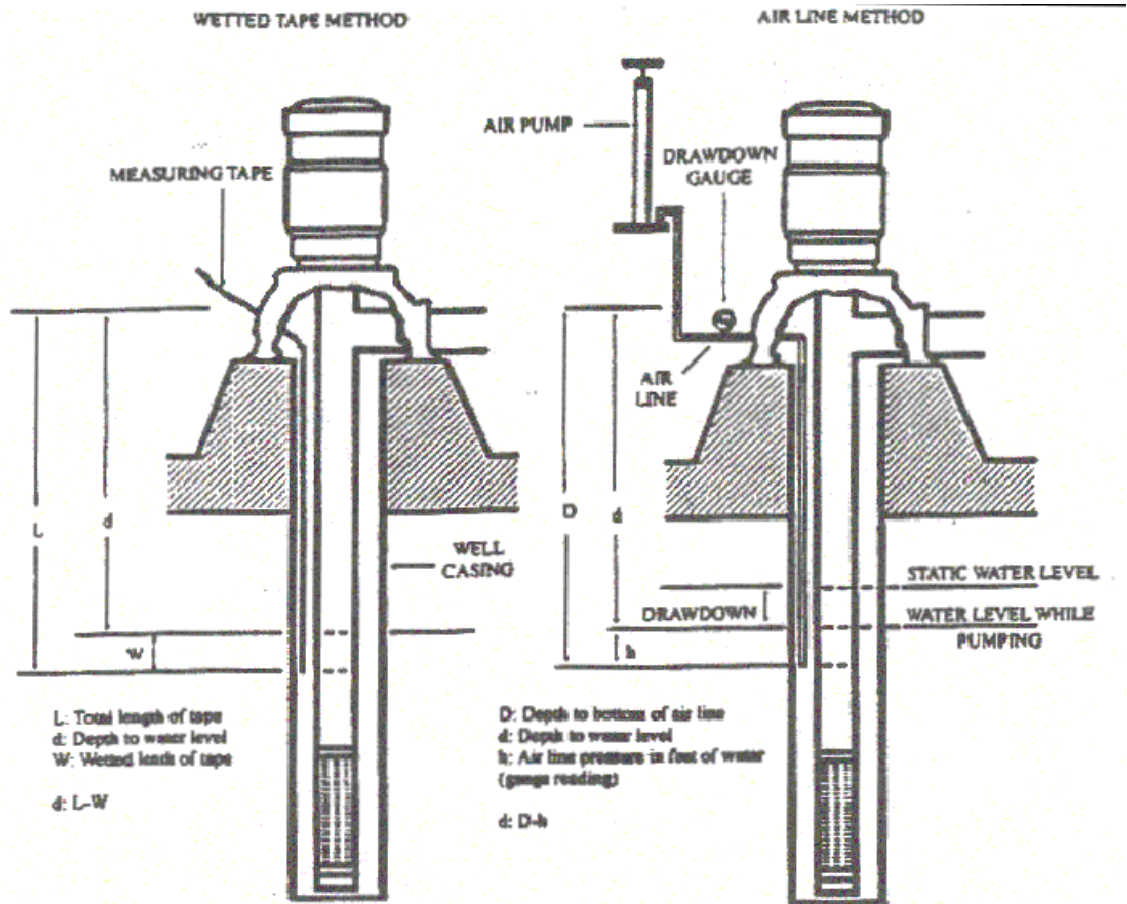

Pump the air into the line until the gauge pressure is constant. This indicates that all of the water has been expelled from the tube. The gauge reading shows the pressure necessary to support a column of water of a height equal to the depth the tube was submerged. If the gauge indicates feet of water, then it shows directly the submerged length of the line in feet. Subtracting the submerged length from the total length of the air line gives the depth to static water level. Gauges calibrated in pounds per square inch (psi) may be converted to feet of water by multiplying by 2.31.

### C. Determination of Drawdown.

First, determine the static water level. Second, after the well has achieved a constant pumping rate or yield, measure the depth to the water level. The difference of these readings before and after pumping the well at a specific rate is measured in feet and recorded as feet of drawdown.

Example:	Depth to water before pumping	=	100 feet
	Depth to water after pumping	=	125 feet

$$\begin{aligned} \text{Drawdown} &= \text{Depth after pumping} - \text{depth before pumping} \\ &= 125 \text{ feet} - 100 \text{ feet} = 25 \text{ feet} \end{aligned}$$

#### D. Determination of Specific Capacity.

Specific capacity is calculated by dividing the yield of the well in gallons per minute by the drawdown. Both measurements shall be taken at the same time.

$$\begin{array}{lcl} \text{Example: Yield of well} & = & 160 \text{ gpm} \quad \text{Drawdown} = 20 \text{ feet} \\ \text{Specific capacity} & = & 160/20 = 8 \text{ gpm per foot} \\ & & \text{of drawdown} \end{array}$$

#### E. Interpretation of Water Well Problems.

With proper records of water well tests, well problems can be interpreted. Some rules to follow are:

1. If the output of the well (gpm) drops, the drawdown decreases, and the specific capacity remains the same, the problem is most likely the pump.
2. If the output of the well (gpm) drops, the static water level remains the same, the drawdown increases and the specific capacity decreases, the well may be plugging. Acid clean the well when the specific capacity drops about twenty-five percent.
3. If the output of the well (gpm) drops and the static water level is declining, the aquifer may be depleting.

### V. GENERAL POLICY - GEOTHERMAL ENERGY

Geothermal energy is the renewable thermal energy of the earth or ground water. Using this form of energy for heating and cooling purposes has become increasingly popular for both commercial and residential purposes. Geothermal regulations are administered by the North Dakota Geological Survey, and require a permit from the State Geologist prior to the installation of a geothermal system. All construction of geothermal energy systems must comply with the rules contained in Chapter 43-02-07, Geothermal Energy Production. These regulations cover both vertical-loop and horizontal-loop systems. Installers should contact the North Dakota Geological Survey for more information regarding installation of geothermal energy systems.

Because of the potential for contamination of drinking water systems and aquifers, and the pollution of surface waters, the North Dakota state department of health provides the following guidance for users of geothermal energy. This policy relates primarily to private individual



systems. Commercial and industrial projects should be constructed only after consultation with the department regarding water supply and disposal requirements and the North Dakota Geological Survey regarding construction permitting requirements.

1. The department encourages the conservation of ground water resources, therefore, closed-loop geothermal systems are recommended. Closed-loop systems also have fewer maintenance problems. If an open-loop system is constructed, whenever possible, the water should be reinjected into the supply aquifer or used for other beneficial purposes such as irrigation or stock watering.
2. Users of open-loop geothermal energy systems must be aware of the scale-forming or corrosive nature of some of the highly mineralized water in North Dakota. Some ground water supplies may require treatment prior to use, or serious problems with operation of the heat exchange system can develop. Chemicals used for cleaning the heat exchange system, and the material removed through cleaning, may not be suitable for discharge to the storm sewer system. Problems with the development of scale will often reduce the volume of water that can be disposed into injection wells.
3. All supply and disposal wells shall be constructed to comply with state department of health rules, chapter 33-18-01, "Water Well Construction and Water Well Pump Installation." The geothermal system should be constructed to eliminate all sources of contamination to the water supply system and the ground water aquifer.
4. If municipal water supply systems are to be used as a source of geothermal energy, an approved backflow prevention device shall be used to separate the geothermal energy from the public water supply system.
5. To protect the drinking water supply, heat exchangers, unless otherwise permitted under the North Dakota state plumbing code, shall be of double-wall construction with a space between the two walls which is vented to the atmosphere.
6. Geothermal energy systems shall not discharge water to either municipal drinking water or sanitary sewer systems. Discharge to the municipal drinking water system is a cross-connection and could result in chemical and/or microbiological contamination of the system. Nearly all cities in the state have sewer use ordinances specifically prohibiting the connection of clear water discharges to the sewer system.
7. Geothermal energy systems may discharge to municipal storm sewer systems with approval of the municipality, and if the discharge water is compatible with the waters of the receiving stream. Degradation of

surface waters by discharges from geothermal energy systems will not be allowed.

8. If water is to be reinjected into the ground water system, the discharge should be made to a similar or inferior quality aquifer.
9. Highly mineralized or saline waters, such as from the Dakota formation, should be returned to those aquifers if secondary use is not possible.
10. Evaporation ponds, which do not discharge, may be used as a means of disposal where other methods of disposal are not feasible.
11. Disposal permits under the Underground Injection Control Program or the National Pollutant Discharge Elimination System Regulations may be required. Users of geothermal energy systems should contact the department to determine whether a permit is required for their installation.

## VI. ABANDONMENT OF TEST HOLES, PARTIALLY COMPLETED WELLS, AND COMPLETED WELLS

Reprinted from AWWA Standard for Water Wells, A100-84, by permission. Copyright © 1984, American Water Works Association.

### Section 1.1 - General

The recommendations contained in this appendix pertain to wells and test holes in consolidated and unconsolidated formations. Each sealing job should be considered as an individual problem, and methods and materials should be determined only after carefully considering the objectives outlined in the standard.

### Section 1.2 - Wells in Unconsolidated Formations

Normally, abandoned wells extending only into consolidated formations near the surface and containing water under water-table conditions can be adequately sealed by filling with concrete, grout, neat cement, clay, or clay and sand. In the event that the water-bearing formation consists of coarse gravel and producing wells are located nearby, care must be taken to select sealing materials that will not affect the producing wells. Concrete may be used if the producing wells can be shut down for a sufficient time to allow the concrete to set. Clean, disinfected sand or gravel may also be used as fill material opposite the water-bearing formation. The remainder of the well, especially the upper portion, should be filled with clay, concrete, grout, or neat cement to exclude surface water. The latter method, using clay as the upper sealing material, is especially applicable to large-diameter abandoned wells.

In gravel-packed, gravel-envelope, or other wells in which coarse material has been added around the inner casing to within twenty to thirty feet [6.1 to 9.1 meters] of the surface, sealing outside the casing is very important. Sometimes this sealing may require removal of the gravel or perforation of the casing.

#### Section 1.4 - Wells in Noncreviced Rock Formations

Abandoned wells encountering noncreviced sandstone or other water-bearing consolidated formations below the surface deposits may be satisfactorily sealed by filling the entire depth with clay, provided there is no movement of water in the well. Clean sand, disinfected if other producing wells are nearby, may also be used through the sandstone up to a point ten to twenty feet [3.0 to 6.1 meters] below the bottom of the casing. The upper portion of this type of well should be filled with concrete, neat cement, grout, or clay to provide an effective seal against entrance of surface water. If there is an appreciable amount of upward flow, pressure cementing or mudding may be advisable.

#### Section 1.5 - Multiple Aquifer Wells

Some special problems may develop in sealing wells extending into more than one aquifer. These wells should be filled and sealed in such a way that exchange of water from one aquifer to another is prevented. If no appreciable movement of water is encountered, filling with concrete, neat cement, grout, or alternate layers of these materials and sand will prove satisfactory. When velocities are high, the procedures outlined in section 1.6 are recommended. If alternate concrete plugs or bridges are used, they should be placed in known nonproducing horizons or, if locations of the nonproducing horizons are not known, at frequent intervals. Sometimes when the casing is not grouted or the formation is nocaving, it may be necessary to break, slit, or perforate the casing to fill any annular space on the outside.

#### Section 1.6 - Wells With Artesian Flow

The sealing of abandoned wells that have a movement of water between aquifers or to the surface requires special attention. Frequently the movements of water may be sufficient to make sealing by gravity placement of concrete, cement grout, neat cement, clay, or sand impractical. In such flow, if preshaped or precast plugs are used, they should be several times longer than the diameter of the well, to prevent tilting.

Since it is very important in wells of this type to prevent circulation between formations or loss of water to the surface or to the annular space outside the casing, it is recommended that pressure cementing, using the minimum quantity of water that will permit handling, be used. The use of wells, large stone aggregate (not more than one-third of the diameter of the hole), lead wool, steel shavings, a well packer, or a wood or cast-lead plug

or bridge will be needed to restrict the flow and thereby permit the gravity placement of sealing material above the formation producing the pressure mudding instead of this process if sometimes permissible.

In wells which the hydrostatic head producing flow to the surface is low, the movement of water may be arrested by extending the well casing to an elevation above the artesian-pressure surface. Previously described sealing methods suitable to the geologic conditions can then be used.

### Section 1.7 - Sealing Materials

A number of materials that can be used for sealing wells satisfactorily, including concrete, cement grout, neat cement, clay, sand, or combinations of these materials, are mentioned in this appendix. Each material has certain characteristics and distinctive properties; therefore, one material may be especially suited for doing a particular job. The selection of the material must be based on the construction of the well, the nature of the formations penetrated, the material and equipment available, the location of the well with respect to possible sources of contamination, and the cost of doing the work.

Concrete is generally used for filling the upper part of the well or water-bearing formations, for plugging short sections of casings, or for filling large-diameter wells. Its use is cheaper than neat cement or grout, and it makes a stronger plug or seal. However, concrete will not penetrate seams, crevices, or interstices. Furthermore, if not properly placed, the aggregate is likely to separate from the cement.

Cement grout or neat cement and water are far superior for sealing small openings, for penetrating any annular space outside of casings, and for filling voids in the surrounding formation. When applied under pressure, they are strongly favored for sealing wells under artesian pressure or those encountering more than one aquifer. Neat cement is generally preferred to grout because it does not separate.

Clay, as a heavy mud-laden or special clay fluid applied under pressure, has most of the advantages of cement grout. Its use is preferred by some competent authorities, particularly for sealing artesian wells. Others feel that it may, under some conditions, eventually be carried away into the surrounding formations.

Clay in a relatively dry state, clay and sand, or sand alone may be used advantageously as sealing materials, particularly under water-table conditions where diameters are large, depths are great, formations are caving, and there is no need for achieving penetration of openings in casings, liners, or formations, or for obtaining a watertight seal at any given spot.

Frequently combinations of these materials are necessary. The more expensive materials are used when strength, penetration, or watertightness are needed. The less expensive materials are used for the remainder of the well. Cement grout or neat cement is now being mixed with bentonite clays and various aggregates. Superior results and lower cost are claimed for such mixtures.

ASTM STANDARD A 53\*  
Welded and Seamless Steel  
Pipe Schedule 40 - Standard Weight

Nominal Size (Inches)	External Diameter (Inches)	Internal Diameter (Inches)	Wall Thickness (Inches)	Weight Per Foot (lb)	
				Plain End	Threads and Couplings
1 1/4	1.660	1.380	0.140	2.27	2.28
1 1/2	1.900	1.610	0.145	2.72	2.73
2	2.375	2.067	0.154	3.65	3.68
2 1/2	2.875	2.469	0.203	5.79	5.82
3	3.500	3.068	0.216	7.58	7.62
3 1/2	4.000	3.568	0.226	9.11	9.20
4	4.500	4.026	0.237	10.79	10.89
5	5.563	5.047	0.258	14.62	14.81
6	6.625	6.065	0.280	18.97	19.18
8	8.625	7.981	0.322	28.55	29.35
10	10.750	10.020	0.365	40.48	41.85
12	12.750	12.000	0.375	49.56	51.15
14	14.000	13.250	0.375	54.57	57.00
16	16.000	15.250	0.375	62.58	65.30
18	18.000	17.250	0.375	70.59	73.00
20	20.000	19.250	0.375	78.60	81.00
22	22.000	21.000	0.500	114.81	
24	24.000	23.000	0.500	125.49	
26	26.000	25.000	0.500	136.17	
28	28.000	27.000	0.500	146.85	
30	30.000	29.000	0.500	157.53	
32	32.000	31.000	0.500	168.21	
34	34.000	33.000	0.500	178.89	
36	36.000	35.000	0.500	189.57	

ASTM STANDARD A 589\*

Water-Well Reamed and Drifted Pipe

Nominal Size (Inches)	External Diameter (Inches)	Internal Diameter (Inches)	Wall Thickness (Inches)	Weight Per Foot (lb)	
				Plain End	Threads and Couplings
1 1/4	1.660	1.380	0.140	2.27	2.30
1 1/2	1.900	1.610	0.145	2.72	2.75
2	2.375	2.067	0.154	3.65	3.75
2 1/2	2.875	2.469	0.203	5.79	5.90
3	3.500	3.068	0.216	7.58	7.70
3 1/2	4.000	3.548	0.226	9.11	9.25
4	4.500	4.026	0.237	10.79	11.00
5	5.563	5.047	0.258	14.62	15.00
6	6.625	6.065	0.280	18.97	19.45
8	8.625	7.981	0.322	28.55	29.35
10	10.750	10.020	0.365	40.48	41.85
12	12.750	12.000	0.375	49.56	51.15

\*From "1973 Annual Book of ASTM Standards"

**SDR RATED PVC CASING - WEIGHTS AND DIMENSIONS**

NOMINAL SIZE	STANDARD DIMENSION RATIO (SDR)	AVERAGE INCHES O.D.	MIN. INCHES WELL	WEIGHT (LBS/FT)		MINIMUM I.D.					
				AIR	S.P.C.-1	ROUND	I.D. AT ADDITIONAL % OUT OF ROUND				
							1%	2%	3%	4%	5%
4"	21	4.500	.214	1.875	.555	3.961	3.921	3.882	3.842	3.803	3.763
	17	4.500	.265	2.292	.678	3.882	3.843	3.804	3.765	3.726	3.686
	13.5	4.500	.333	2.831	.838	3.730	3.693	3.655	3.618	3.580	3.544
5"	21	5.583	.265	2.570	.850	4.908	4.860	4.811	4.762	4.713	4.664
	17	5.583	.327	3.497	1.035	4.781	4.743	4.696	4.647	4.598	4.552
	13.5	5.583	.412	4.341	1.285	4.601	4.555	4.509	4.463	4.417	4.371
6"	21	6.625	.316	4.074	1.206	5.856	5.797	5.738	5.680	5.621	5.563
	17	6.625	.390	4.966	1.470	5.705	5.648	5.590	5.534	5.476	5.420
	13.5	6.625	.491	6.144	1.819	5.481	5.426	5.371	5.317	5.262	5.207
8"	21	8.625	.410	6.884	2.038	7.817	7.541	7.464	7.388	7.312	7.236
	17	8.625	.508	8.421	2.493	7.427	7.353	7.278	7.204	7.130	7.056
10"	21	10.750	.511	10.693	3.185	9.516	9.421	9.325	9.230	9.135	9.040
12"	21	12.750	.608	15.042	4.452	11.302	11.189	11.076	10.963	10.849	10.736
18"		16.000	.762	23.748	7.029	14.235	14.093	13.950	13.808	13.666	13.523

Polyvinyl Chloride (PVC) casing for water wells will carry the following labels for compliance with the American Society for Testing and Materials (ASTM) specification F480-81.

**8" WELL CASING PVC 1120 SDR 21 IC2 F480 NSF-WC**

This label includes the SDR, IC number, and the NSF-WC logo.

**8" WELL CASING PVC 1120 200 PSI SDR 21 IC2 F480 NSF-WC D2241 NSF-PW**

This label is the same as the first except it has also been tested as ASTM D2241 pressure pipe; therefore, the label includes the NSF-PW logo, as well as the NSF-WC logo.

**NOTE:** A label will also include the manufacturer's name and production code number, which are not included in the above labels.



